

Operating Instructions

Plumb-up Laser LL-80/-81
Plumb-down Laser LL-82/-83



Congratulations on your new GEO laser

This operating instructions contain enclosed in addition to information on how to use the laser **important safety information**.

Please note: First read the safety instructions on the supplement page 1 - 3 and then the operating instructions carefully before using the laser.

1. Description

The laser emits an automatically levelled plumb laser beam as reference axis. This laser beam is, for example, represented as dot on a target. If the target is connected to sliding moulding, the moulding can be controlled according to the position of the laser dot. The LL is a special laser for all types of plumbing operations. Its possible uses are virtually unlimited.

2. Buttons

2.1 On/Off Button

The device is switched on by pressing this button. After the levelling phase the laser beam and green LED stop blinking. If this does not happen, the device must be moved into the levelling range by tilting it forwards. To switch off the device, press the ON/OFF button until the right LED lights up orange.



2.2 Operating LED

Constant:	Ready for operation
Blinks quickly:	Levelling not finished
Blinks slowly:	Self-levelling range exceeded
Rhythmically with pause:	Temperature range exceeded (> 50°C)
Green light:	Power supply okay
Red light:	Charge battery

2.3 Automatic Laser Cut-Out LED (kick guard)

The laser beam is switched off automatically as a precautionary measure in the event of a jerky movement (bump). The right LED then begins to blink unrhythmically. The laser beam must then be switched on again by briefly pressing the ON button and the positioning checked and corrected if necessary. To deactivate the function when switching on, keep the ON button pressed until the left LED blinks green briefly.

2.4 Laser Power (only LL-81/-83)

After switching on the laser, power is < 5 mW. By pressing the button, the power is changed to approx. 1, 2, 3, 4, 5, 1, 2, mW. At the same time the LED 2.3 is blinking quickly 3 x green when < 1 mW and 3 x red when > 1 mW.

3. Monitoring of Self-Levelling

The self-levelling function corrects even the smallest deviations. At a deviation of approx. 0.01% the laser beam and right LED begin to blink.

4. Power Supply

4.8 V DC internal rechargeable battery or 12 V DC external rechargeable battery in combination with converter cable 0117.00 or continuous operation from 110 to 230 V mains with the power supply NE-05.

5. Charging the Battery

- The battery is charged with the battery charger type LG-80.
- Protect the battery charger against moisture and only use indoors.
- Take the laser out of the transport case for charging.
- Do not charge in sub-zero temperatures.
- The charging time is finished after approx. 4 hours; the charge LED begins to blink.
- The battery only reaches its full capacity after several charging and discharging cycles.
- Defective NiCd batteries must be disposed of in accordance with local regulations.

6. Adjustment

6.1. Checking the Adjustment

Set up the laser standing upright and mark the laser beam at the required measuring distance. Turn the laser by 180° and mark again. If the adjustment is correct, the first marking does not deviate from the second. If there is a deviation, the target axis lies in the middle between the first and second marking.

6.2. Adjustment

The laser can be adjusted in the field without having to open the device. For safety reasons, however, adjustment should only be carried out by authorized personal. See the special adjustment instructions in this regard.

7. Troubleshooting

1. No laser beam - check battery charge.
2. Low range - clean laser beam exit window.
3. Laser beam blinks slowly - move device into the levelling range by tilting forwards. If the error is not corrected within 2 ½ minutes, the device is switched off automatically.
4. Laser switched off automatically (kick guard) - see 2.3.

8. Maintenance

The laser requires no special maintenance. Keep the electrical connections clean. Do not clean with water spray. Clean glass parts with a soft, clean cloth. Store dry. Always transport the laser in its original case.

9. Dimensional Sketch

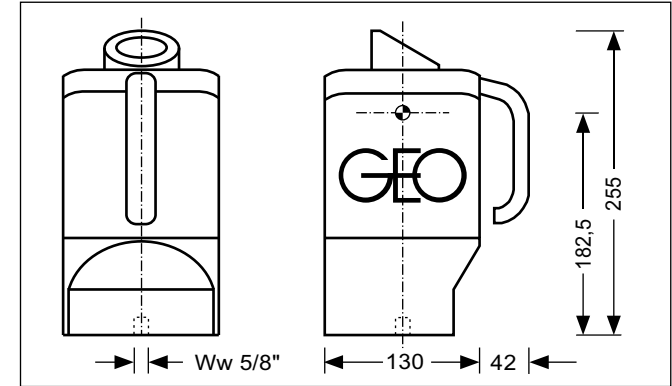

10. Technical Specifications

Laser class LL-80/-82:	2, < 1 mW
Laser class LL-81/-83:	3 R, < 5 mW
Laser:	diode laser, visible red, 635 nm
Beam diameter:	13 mm at laser
Range LL-80/-82:	to 200 m
Range LL-81/-83:	to 500 m
Self-levelling range:	± 5 %
Permissible deviation:	± 5 mm/100 m
Operating time:	NiMh battery to 40 hours
External power supply:	11 to 14 V DC with cable 0117.00
Low battery cut-out:	yes
Watertight:	to 3.5 m
Temperature range:	- 10° C to + 50° C
Weight:	3.4 kg
Adjustment:	possible in the field without having to open the device
Guarantee:	24 months
CE:	certificate

